

Warning
For proper use and maintenance refer to the user's handbook attached to the torch.

Attenzione
Consultare il manuale di uso e manutenzione allegato alla torcia.

Achtung
Bitte unbedingt das beigefügte Bedienungshandbuch beachten.

Attention
Consultez le manuel d'utilisation et de manutention joint à la torche.

Operating instructions
The excessive wear of tip and electrode may cause some damage to the torch head. Replace the electrode before its total consumption as well as the tip when showing an irregular hole or an increased diameter.

Modalità d'uso
L'eccessiva usura di cappa ed elettrodo può creare danni al corpo torcia, sostituire l'elettrodo prima del totale consumo dell'inserto e la cappa quando presenta un foro irregolare o di diametro maggiorato.

Gebrauchsanweisung
Elektrode und Schneiddüsen sollten auf den Verschleiß hin überprüft werden, überhöhte Beanspruchung führt zu verschlechterten Schneidergebnissen und kann zu einer Beschädigung des Brennerkörpers führen.

Modalité d'usage
L'usure excessive de la tuyère et de l'électrode peuvent causer des dommages au col de cygne, remplacer l'électrode avant l'usure totale de l'insert en HF ainsi que la tuyère si celle-ci présente une "usure irrégulière" ou un diamètre majoré.

Check the state of the swirl ring. Air holes must be open. If not, the low cooling system will damage the torch head.

Controllare lo stato di efficienza del diffusore aria, che deve sempre presentare i fori di accesso aria liberi da occlusioni.

Überprüfen des Luftverteilers, das die Löcher nicht verstopft sind.

Contrôler le rendement du diffuseur d'air dont les trous d'accès d'air doivent rester libres de toutes occlusions.

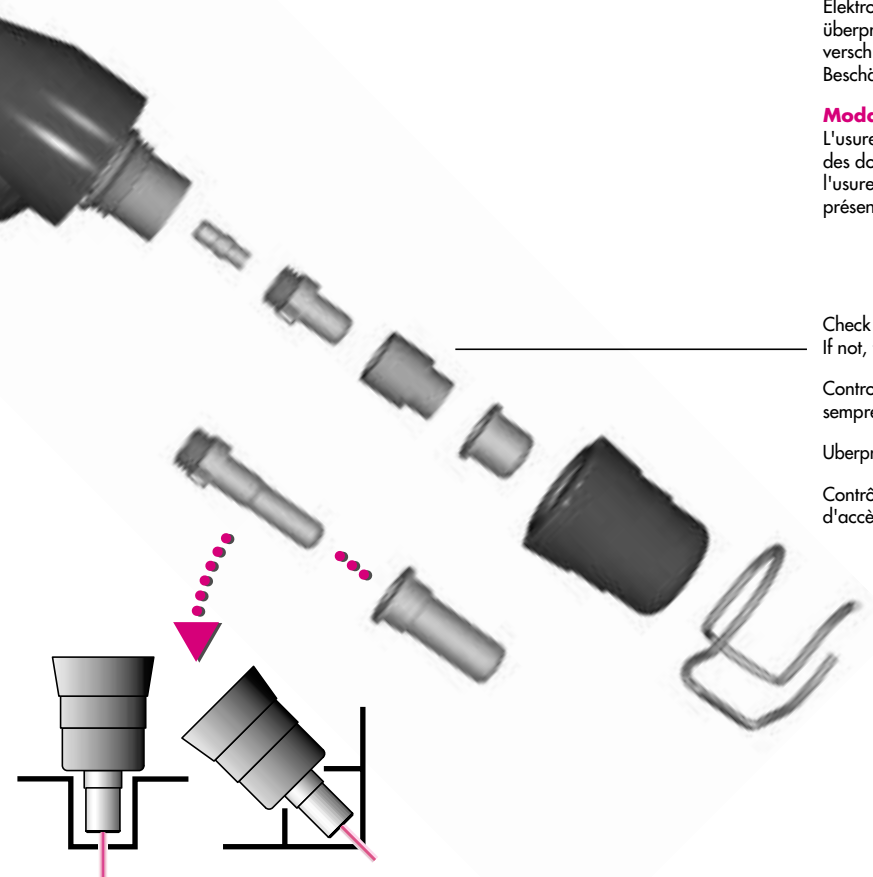

The parts advertised for sale are not genuine parts, but are parts made for and by TRAFIMET. References to manufacturer equipment, and/or trade names or trade-marks, are for identification and convenience only.

TRAFIMET spa claims that all items on this catalogue are manufactured in conformity with the "low voltage" CE 73/23 directive as per EN 50078 and EN 50192 standards. The company reserves the right to modify any of its products without notice.

TRAFIMET spa is the registered owner of all trademarks, patents and models.

Copyright © February 1997 • by TRAFIMET spa (Print 11/99) EA 0525



CB 70 MANUAL
CB 70 P AUTOMATIC
PLASMA TORCHES



CB 70 P

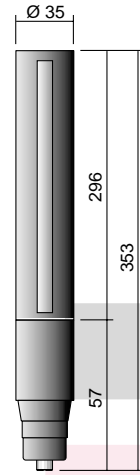
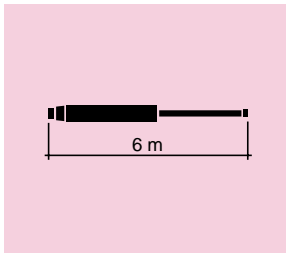

Technical data CB 70 • CB 70 P	
Voltage class	M
Standard length	6 m
Air consumption	170 l/min
Air pressure	5 bar
Duty cycle 100%	50 A
Duty cycle 60%	70 A

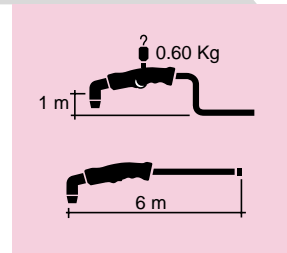

CB 70

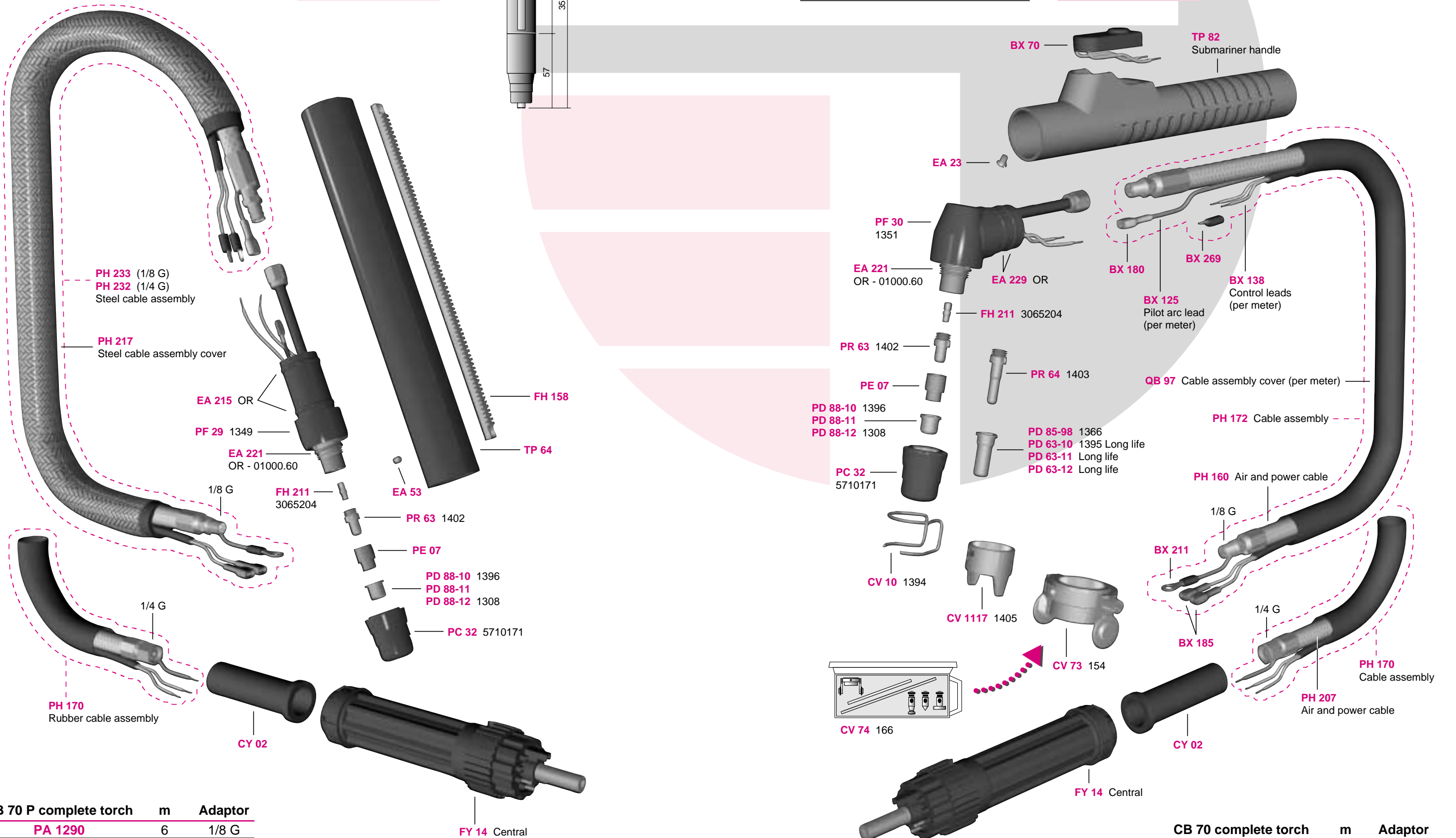

CB 70 P complete torch	m	Adaptor
PA 1290	6	1/8 G
PA 1291	6	Central

Steel cable available on request.

CB 70 complete torch	m	Adaptor
PA 1270	6	1/8 G
PA 1272	6	Central